

# Big Bird

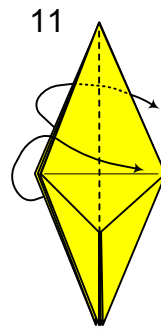
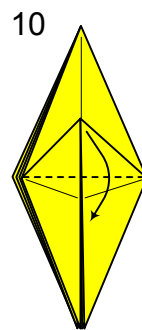
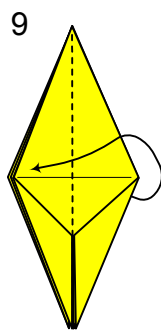
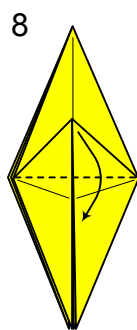
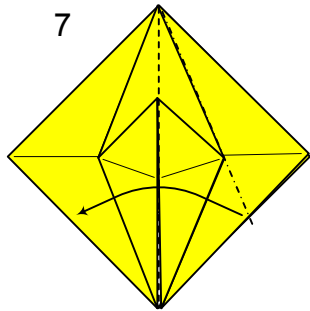
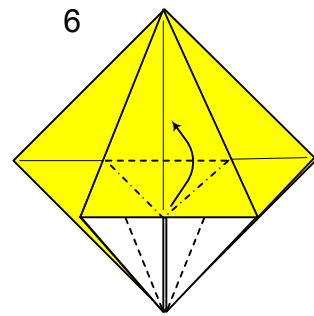
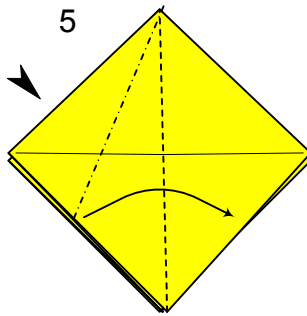
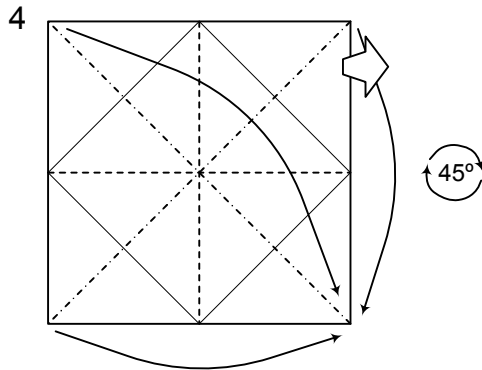
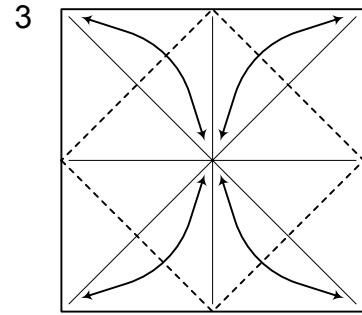
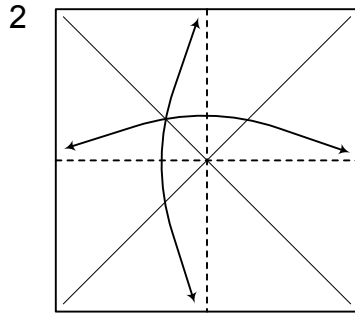
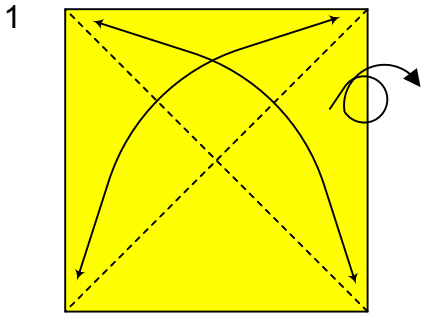

Repeat steps 5 and 6 on the other 3 sides

Fold 2 layers to the left

Fold 1 layer to the right (front and back to even up the layers on each side)

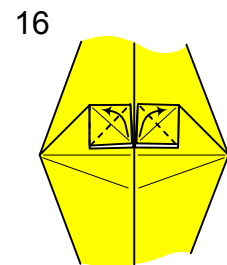
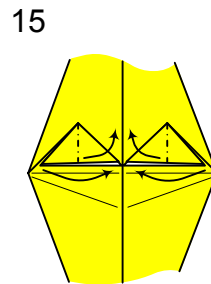
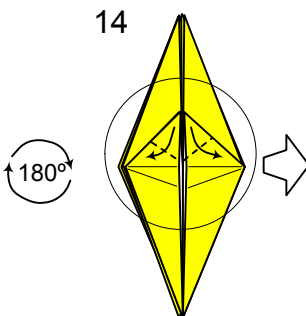
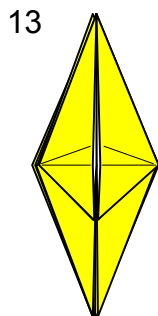
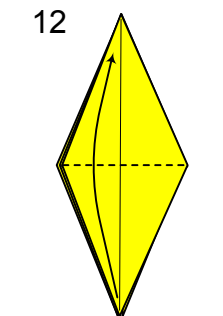

Fold 1 layer to the top

Valley fold the 2 small points. Note that the lower edges are slightly above the centre crease

Squash fold asymetrically or see the box below

An alternative is to squash fold symetrically, this is a bit fiddly but the eyes will eventually look like this

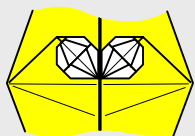

Much harder still, if you form tiny 'bird bases' on the centre layers, the eyes turn out like this

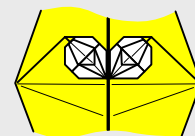

# Big Bird

17

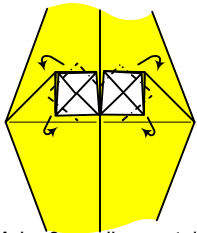

Make 3 small mountain folds to round off each eye

18

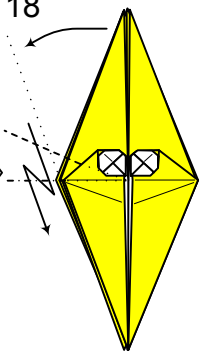

Swivel a point to the left so that it continues the line of the bottom edge

19

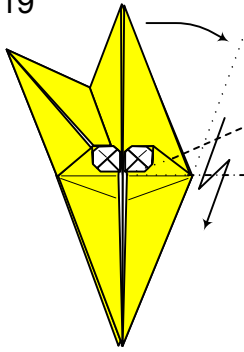

Swivel the other point to the right

20

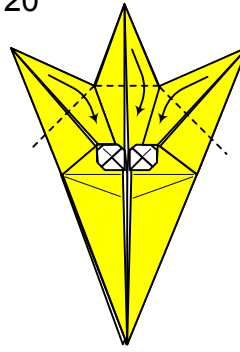

Valley fold the three points to the centre

21

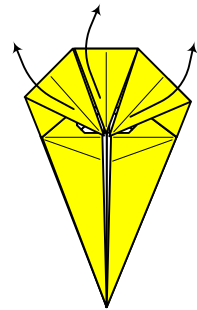

Unfold

22

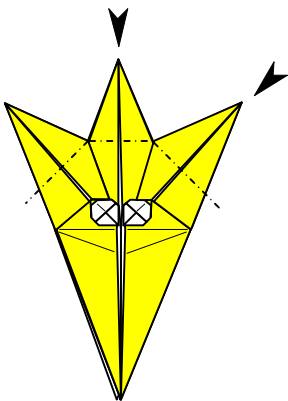

Inside reverse fold the 3 points

23

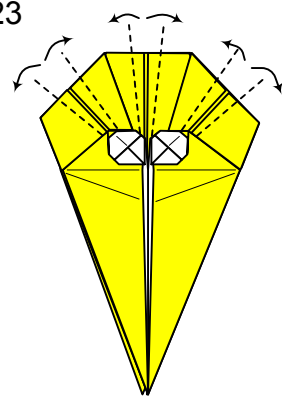

Make small valley fold to form feathers

24

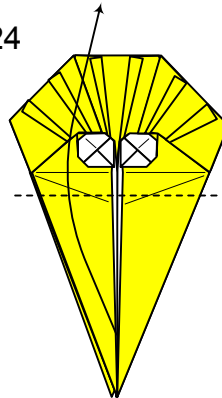

Valley fold the point up note that the horizontal crease is slightly above the existing diagonal crease

25

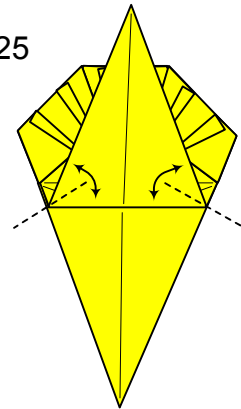

Make 2 sharp creases about half way to the centre line

26

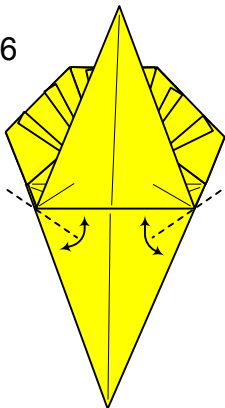

27

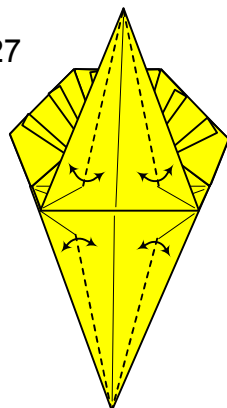

These creases should be made lightly, just bending the paper

28

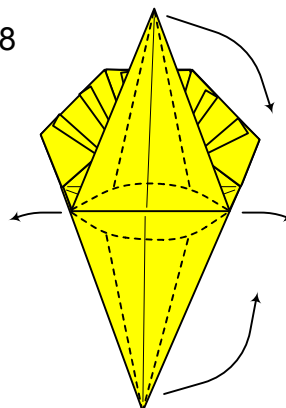

Make the beak 3-dimensional, gently curving the head back

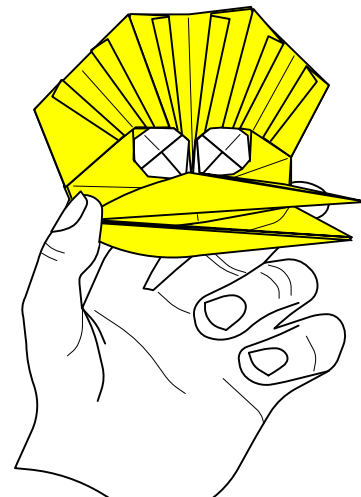

Gently squeeze the sides to make the beak open and close